

HYUNDAI
POWER PRODUCTS

PETROL BRUSH CUTTER & GRASS TRIMMER

HDBT52-A

ORIGINAL INSTRUCTIONS

Read carefully this manual before any use

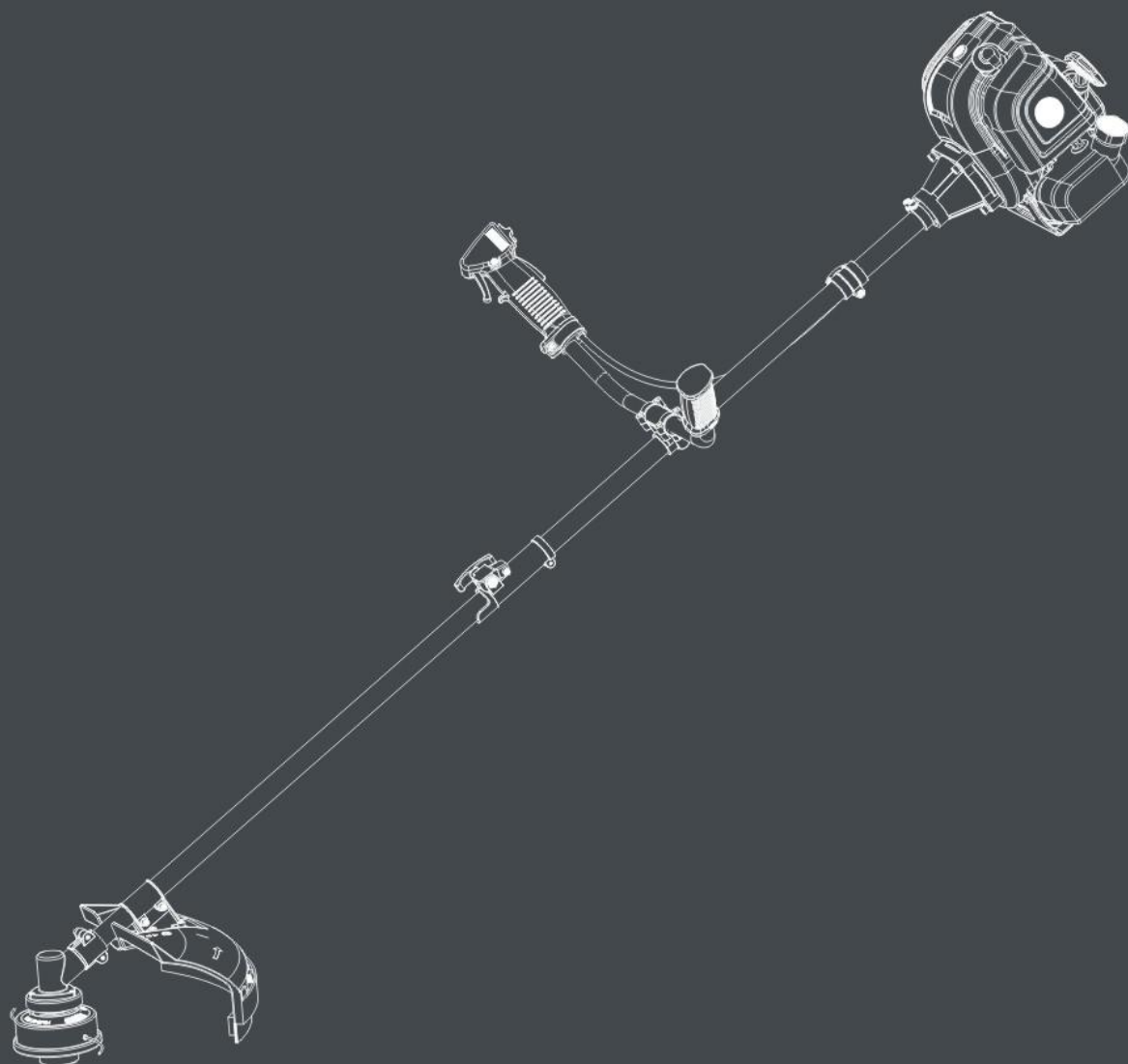

CONTENT

1. SAFETY WARNINGS	3
2. PRODUCT DESCRIPTION	8
3. ASSEMBLY	11
4. FILLING FUEL TANK	13
5. OPERATION	14
6. MAINTENANCE & CARE	16
7. TROUBLE SHOOTING	18
8. DECLARATION OF CONFORMITY	19
9. WARRANTY	20
10. PRODUCT FAILURE	21
11. WARRANTY EXCLUSIONS	22

1. SAFETY WARNINGS

- **WARNING!** When using this type of tool, basic precautions should always be followed to reduce the risk of fire and injury.
- Read all instructions carefully before attempting to use this product and retain these instructions. Be familiar with all the operations described in these operating instructions. This product must be operated by experienced users.
- Inexperienced users shall first have training in all operations with a professional.
- If you are giving this machine to others, please also provide them with this instructions manual.
- Read all markings affixed on the product (symbols, stickers, technical data, etc.). The symbols are explained in this manual.
- Use this machine as described in this instruction manual. It is strictly forbidden to use this tool for applications other than those described in this manual.
- Failure to follow these instructions can result serious injuries and, in some cases, death.
- This product is intended for private domestic use only. Do not use it for commercial purposes.
- Never let people unfamiliar with these instructions or children use this product.
- National regulations may limit the use of the machine.
- People under the age of 18 must not use this product
- Keep in mind that the operator or user is responsible for accidents or risks to other persons or their property.
- **WARNING:** Do not use of the unit when tired, ill or under the influence of alcohol or other drugs.
- Do not use the tool if you are not in an adequate physical condition.
- This tool is intended for outdoor use. Never use it indoors.
- Secure the machine during transport to prevent loss of fuel, damage or injury; always install the protection device on the blade, check the cap of the fuel tank, and do not transport the tool upside down.
- Keep people and animals away from the work area. Children and people who do not know how to use this tool should not touch it and handle it.
- **WARNING:** Keep people at least 15 m from the machine during operation.
- Use the product only under daylight or under good artificial light.
- When using the machine, always wear full protective equipment including a protective helmet, protective mask, hearing protection, ocular protection, gloves, slip-resistant foot protection and protective clothing. The protective equipment shall be in conformity with the European norms.
- Wear appropriate clothing. Do not wear loose or unbuttoned clothes. Do not wear jewellery that may come in contact with moving parts. If you have long hair, tie them down and wear an appropriate safety helmet.
- Do not operate the product with damaged guards or shields not in place.
- Keep hands and feet far away from the cutting parts at all times and especially when switching ON/OFF the tool.
- Do not use the tool in an area where ventilation is poor. Gas emissions can cause injury.
- Do not work when it rains and in bad weather. Do not use the tool in damp locations.
- Do not use the tool in the presence of flammable liquids or gases.

- Keep the work area clear. Before working, inspect the work area and remove any materials or objects that could cause accidents.
- Do not force the tool.
- Use only accessories and guards supplied or recommended by the manufacturer. The use of non-recommended accessories (e.g. metal multi-piece pivoting chains and flail blades) may result an accident. Ask your dealer for advice.
- Keep firm footing and balance during operation. Always use the harness provided.
- Have a correct working posture; stay stand, do not lean. The working positions should be changed regularly.
- Always inspect the machine before and after operation. If the tool is damaged or faulty, stop using the tool and bring it to an authorized service for inspection and repair.
- Be concentrated when using the tool. Look at what you do, make sense and do not use the tool when you are tired.
- Remove the blade guard before using the tool.
- A damaged part must be properly repaired or replaced by an authorized service center, unless otherwise specified in this instruction manual.
- Do not use the tool if the switch is not working (if it cannot be turned ON or OFF).
- Immediately stop the tool in the event of a malfunction of the motor or in case of unusual noise.
- Do not use the tool if the starter is damaged.
- Avoid any contact with the cutting attachment during operation; they can cause severe cuts.
- When not in use, the machine must be stored in a dry, locked place out of the reach of children.
- Before using the tool and after any impact, please check for signs of wear or if it is not damaged. If repairs are required, they should be done by a qualified service.
- Always switch off the machine:
 - Every time you leave it unattended;
 - Before inspection and maintenance
 - after hitting a foreign object;
 - When abnormal vibration occurs;
 - During the replacement of parts.
- Do not use the product on a slippery surface.
- Do not use the product on steep, slippery slopes.
- When planning your work schedule, allow enough time for rest. Limit continuous use of the tool. For example, do 30 ~ 40 minute sessions interspersed with a 10 ~ 20 minute break. Work a maximum of two hours a day.
- If the machine has struck foreign objects, check if the tool is damaged and bring it to repair if necessary.
- Keep handles dry, clean and free of oil and grease. Oily, greasy grips are slippery and cause loss of control.
- Be careful when using the machine during stormy weather. Do not use the machine during lightning and thunderstorms.
- Warning - When operating the tool, be careful of the emission of exhaust gases, avoid to be exposed to these and wear protective equipment.

- For machines with a clutch, check regularly that the cutting attachment stops turning when the engine idles.
- Check the tool before and after use. Check for loose fasteners, fuel leaks and damaged parts, such as cracks in the cutting attachment. If the tool is damaged, if parts are missed or meet some dysfunctions, do not use the tool and bring it to a service agent for inspection and reparation.
- Check the tool after dropping or other impacts to identify any significant defects; if any defects are observed, stop to use the tool and bring it to a service agent for inspection and reparation.

Fuel Handling

- Be very careful when handling fuels. They are flammable and the vapors are explosive.
- Use only an approved container.
- Never remove the fuel cap or add fuel while the machine is on. Turn off the unit and allow the engine and exhaust components to cool before refuelling.
- Do not smoke.
- Never refuel inside a room.
- Never store the tool and the fuel tray indoors where there is a naked flame, such as near a water heater.
- If fuel has spilled, do not attempt to start the machine, but rather move it away from the spill before starting to use it. Clean any spills.
- Replace and tighten the fuel tank cap after refuelling.
- Follow the instructions in this manual for filling the tool with fuel.

Maintenance and storage

- Stop the tool and wait until it stops. Make sure all moving parts have come to a standstill.
- Allow the machine to cool before performing inspection, adjustments, maintenance, servicing and storage.
- Maintenance and cleaning shall always be done after operation. Follow the instructions given in this manual for maintenance, cleaning and storage.
- Store the tool where fuel vapors will not reach a flame or spark.
- During transport, maintenance and storage, always install the cover on the metal blade.
- When the machine is placed in storage for a long time, drain the fuel tank clean the parts. Move the machine to a safe place and confirm that the engine is cooled down.

Kickback and related warnings

- Kickback is a sudden reaction to a pinched or hung rotary fitting (or other accessory). Pinching or catching causes the rotary attachment to stop quickly, which in turn tilts the tool in the opposite direction.
- Kickback is the result of improper use of the tool and / or procedures or conditions of use and can be avoided by taking the precautions indicated as indicated below:
 - Never place your principal close to the rotary accessory. The accessory may bounce off your hand.
 - Do not place your body in the area where the use will move if the rebound occurs. The rebound will propel the tool in the opposite direction to the movement.
 - Sharp parts and edges tend to catch the rotating accessory and cause loss of control or kickback. Take extreme care when using the tool on sharp edges.

Residual risks

Even if you use this product in accordance with all safety requirements, the potential risk of injury and damage remains. The following hazards may arise:

- There are harmful health consequences resulting from the emission of vibrations if the product is used for long periods of time or not managed adequately and properly maintained. The vibrations can produce the so-called “white finger” disease. If any of the symptoms of "white finger" syndrome appear, see a doctor immediately. Symptoms of the "white finger" include: numbness, loss of sensitivity, tickling, tingling, pain, loss of strength, colour changes, or skin condition. These symptoms usually appear on the fingers, hands or wrists. The risk increases at low temperatures. To reduce this risk, please wear gloves and keep your hands warm. Limit the operating time.
- There is a risk of hearing loss during prolonged use, in particular if you do not wear hearing protection. Always wear hearing protection and limit the operating time.
- Cuts if no suitable protective clothing is worn.
- Inhalation of particles and exhaust gases if a mask of protection is not worn.
- Contact with projected objects.
- Burns when touching with hot surfaces.





Intended use

This machine can be used as a trimmer with the cutting edge, and as a brushcutter with the cutting blade.

The grass trimmer must be strictly and only to cut grass or weeds that are not too dense. The brush cutter must be used to cut hard grass, more dense weeds and small branches with a maximum diameter of 10mm.

This machine is not intended to cut bushes or others similar plants requiring the tool to get off the ground. Do not use this tool to work other materials such as stones, clay soils, etc.

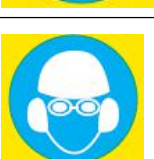
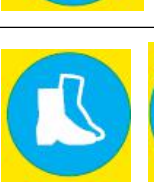
Symbols

	This graphic accompanied by the words WARNING and DANGER calls attention to an act of a condition which can lead to SERIOUS INJURY.
	READ & UNDERSTAND Operator’s Manual and Safety Manual
	ALWAYS WEAR EYE PROTECTION, EAR PROTECTION AND HEAD PROTECTION.
	WEAR FOOT PROTECTION
	WEAR GLOVES



BEWARE OF FOOT INJURY BY CUTTING ATTACHMENT



PAY ATTENTION THAT BYSTANDERS ARE NOT INJURED THROUGH FOREIGN OBJECTS THROWN FROM THE MACHINE.



BEWARE OF THROWN OBJECTS HIT BY CUTTING ATTACHMENTS. NEVER USE WITHOUT PROPERLY MOUNTED BLADE GUARD.
BEWARE OF BLADE THRUST.

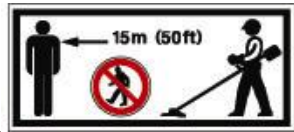

KEEP BYSTANDERS AT LEAST 15 M AWAY.



DO NOT USE SAW BLADE.



GUARANTEE SOUND POWER LEVEL



RISK OF HOT SURFACE



DO NOT EXPOSE TO FIRE

2. PRODUCT DESCRIPTION

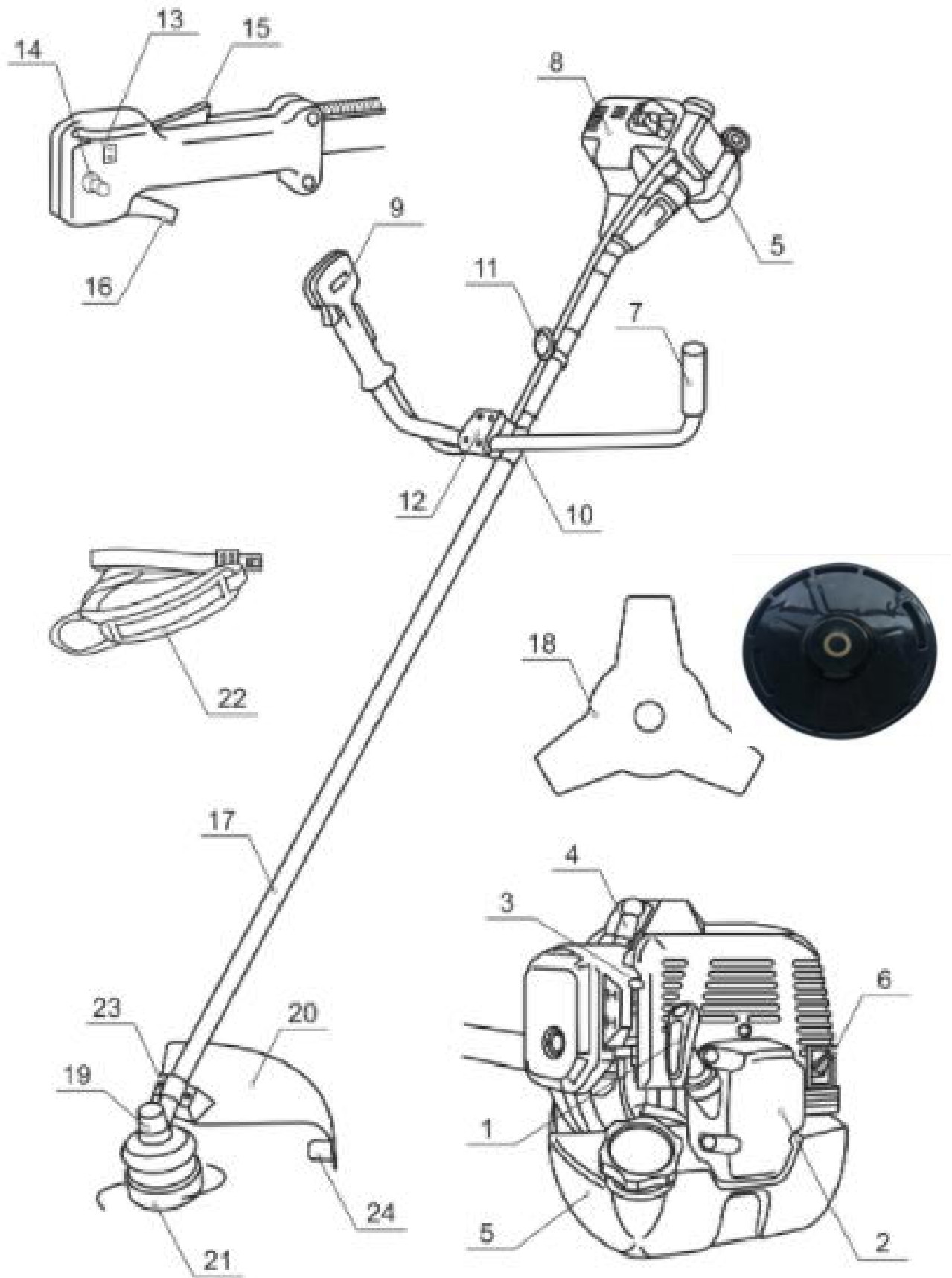

fig. 1

a. Description

1. Starter handle
2. Starter
3. Throttle valve control lever
4. Plug cables
5. Fuel tank
6. Exhaust pipe
7. Left handle
8. Engine casing
9. Right handle
10. Lower part for attaching the handle
11. Shoulder strap ring
12. Upper part for attaching the handle
13. Switch (on/off)
14. Gas throttle trigger (no included for this model)
15. Gas throttle lock
16. Gas throttle lever
17. Pipe and engine connection
18. Cutting head / blade/NYLON
19. Lower gearbox
20. Protective cover
21. Coil with nylon thread
22. Strap
23. Mounting plate for the protective cover
24. Casing knife

b. Technical data

MODEL		HDBT52-A
Main unit	Remote type	Centrifugal Clutch; Hard transmission
	Maximum rotational frequency of the spindle	9,500/min
	Idle speed of engine	3,000 /min
	Measured vibration emission value at each manipulation (m/s ²) (According to ISO 22867)	Brush cutter: 7.824m/s ² , K=1.5 m/s ² Grass trimmer: 8.856 m/s ² , K=1.5 m/s ²
	Measured sound pressure level at operator's position	Brush cutter: Idle:81.1 dB (A), Racing:99.4dB (A) Grass trimmer: Idle:93.0 dB (A), Racing:108.0 Racing: K=3 dB (A)
	Guaranteed sound power level	112 dB (A)
	Line Max. Cutting Path /Diameter of line	43 cm(φ2.4mm)
	Metal blade (Type/Diameter)	3-tooth Ø255xØ25.4x1.4mm
	Weight	8.1kg
Engine	Name of engine	1E44F-5
	Type	Air-cooled; 2 cycle; vertical Piston valve; gasoline engine
	Displacement(cm ³)	52 cm ³
	Maximum output(kW) (in accordance with ISO 8893)	1.45kW 7500/min
	Maximum speed of engine (/min)	9500
	Specific fuel consumption at max. engine performance (g/kWh)	≤695
	Carburetor	Diaphragm-type
	Ignition	CDI ignition
	Method of starting	Recoil type
	Fuel used	Gasoline mixed with lubricating oil (ratio of 40:1)
	Fuel tank capacity(cm ³)	1200

3. ASSEMBLY

HANDLE INSTALLATION

Remove the upper part of the handle attachment (1) by unscrewing the 4 screws. Install the operating handles (3 and 5). The right-hand grip (3) is equipped with engine controls, the trigger of the right-hand grip should be directed toward the gearbox.

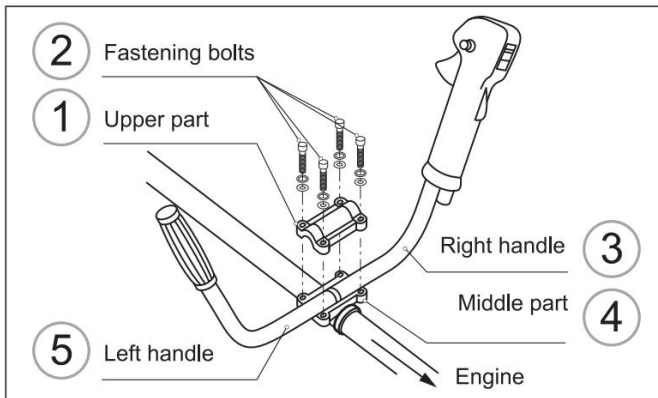

Install the rod assembly to the engine using four screws.

Adjust the comfortable position of the handles and eyelets for the shoulder strap.

Hook the shoulder strap to the eyelet

Assembly of the carter of protection

- Install the carter of the protection on mounting plate; make sure that the holes are aligned.
- Screw the carter of protection with the 2 screws.

NOTE: the carter of protection shall be always installed.

Assembly of the 3-teeth blade (for brushcutting)

Warning - sharp edges; wear gloves when manipulate the blade.

- Insert a metal locking tool in the hole on the side of the drive sprocket and on the drive.
- Remove the retaining nut, the cover bell and the plate.
- Install in the following order, on the shaft: the blade, the plate, the cover bell.
- Screw with the retaining nut.
- Remove the metal locking tool.

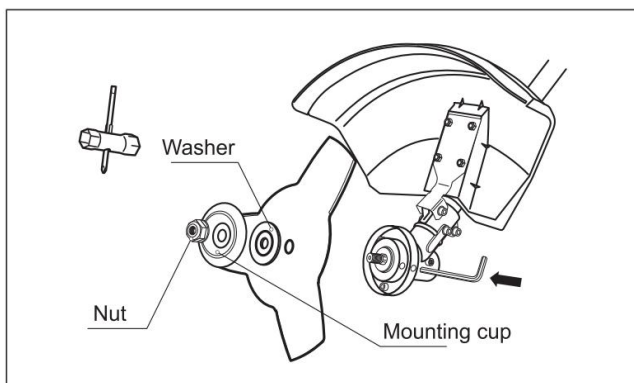

To disassemble the blade, insert a metal locking tool in the hole on the side of the drive sprocket and on the drive.

Loosen the retaining nut and then remove all elements.

NOTE

After installation, always check if the installation is correct. If blade is not well installed, it will vibrate excessively and can cause injury. When operation, if there is abnormal vibration, immediately stop the tool and check the installation.

Assembly of the nylon cutting head (for grass trimming)

- Insert a metal locking tool in the hole on the side of the drive sprocket and on the drive shaft.
- Remove the retaining nut, the cover bell and the plate.
- Install and screw the nylon cutting head.
- Remove the metal locking tool.

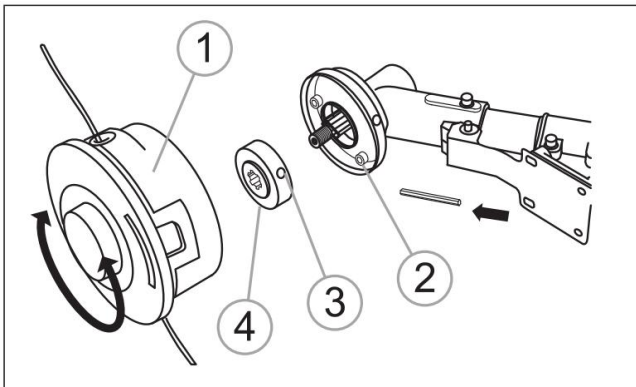

To disassemble the nylon cutting head, insert a metal locking tool in the hole on the side of the drive sprocket and on the drive. Unscrew the nylon cutting to remove it.

Installing the harness

- Put on the harness.
 - If necessary, adjust the bands of the harness to have the blade parallel to the ground when standing in your normal working position to provide you most effectiveness and comfort on operating the machine.
 - Install the hook on the main unit to attach the harness.

Quick release mechanism

Pull the strip to release the machine from you in the case of emergency.

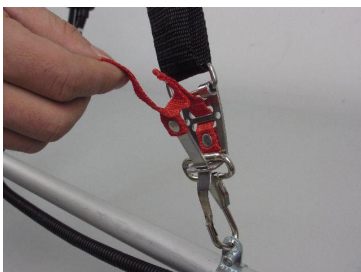

4. FILLING THE FUEL TANK

1) Filling fuel tank

WARNING: When filling the tank:

- The tool must always be stopped and cooled.
- Never smoke during refueling. It must not have flames or sparks near the fuel.
- Before refueling, allow the chainsaw to cool completely. Do not attempt to refuel when the engine is hot.
- If fuel has been spilled, immediately stop refueling and do not start the engine. Clean up the spill and fill the machine in another location
- Never fill the fuel tank to the flange; there is a risk of overflow.
- Do not refuel in a closed and unventilated area.

The fuel used for this tool is a mixture of unleaded gasoline and registered engine lubricant. When mixing gasoline with oil, use only gasoline that does not contain ethanol or methanol.

Unleaded gasoline is a quality gasoline type. This will help to avoid damaging the fuel lines of the engine and other engine parts.

The recommended mixing ratio is 40:1 (make sure the mixing ratio is correct before filling the product).

a. Mixing

- Mix in a clean, empty container (supplied).
- Pour the oil into the container.
- Pour the fuel into the tank. Mix the mixture long enough (more than one minute) to get a good combination.

b. Filling the fuel tank

- Unscrew the fuel tank cap and remove it.
- Fill the tank slowly with the mixture. Do not exceed the maximum capacity (fill to 80% of its capacity preferably).
- Replace the cap on the fuel tank and tighten it.
- Wipe any spillage around the unit if necessary

NOTE: To avoid damage and accidents, DO NOT USE OTHER MIXTURES AND OTHER TYPES OF OIL / PETROL

c. Storage of fuel

The fuel must be kept in a clean and safe container and always closed.

If you are not using the product for a long time, remove the fuel mixture and add it to a container.

Do not leave the fuel for a long time in the product. The fuel may clog the carburetor and the engine will not operate properly.

d. Disposal of fuel

When the fuel is no longer used or worn, please dispose of it in an authorized location. Check local laws regarding disposal of fuels.

5. OPERATION

a. Starting the operation

■ Cold starting

- Switch on the tool by putting the Start/stop button on the position I (ON).
- Push the primer bulb 5-7 times, until fuel comes into the primer bulb.

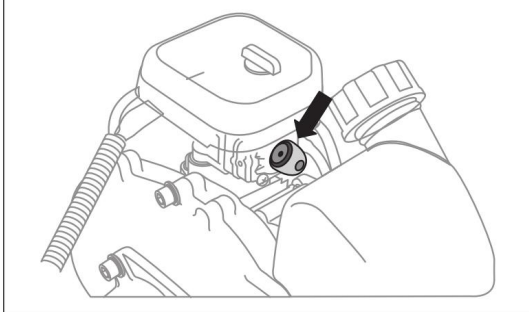

- Pull the choke lever to the OFF position.
- Pull the starter cord until the engine starts.

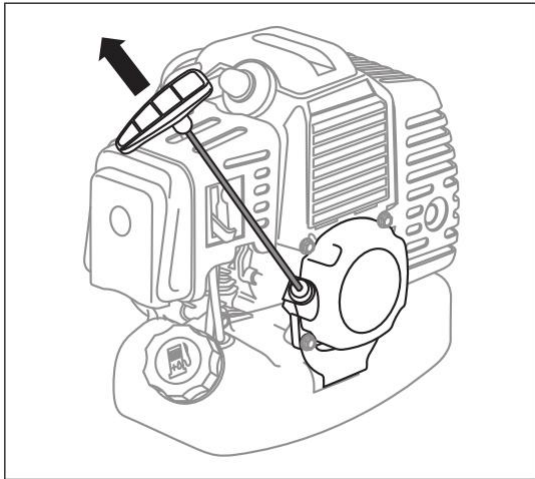

- Pull the choke lever to the ON position.
- Allow engine to warm up for a few minutes before using.
- Push the safety switch then the throttle trigger to start the operation

■ Warm starting

The warm starting can be done when the tool was switched off but still hot.

- Switch on the tool by putting the Start/stop button on the position I (ON).
- Push the primer bulb 5-7 times, until fuel comes into the primer bulb.
- The choke lever must be kept in the ON position. If it is not the case, restart the machine by performing a cold starting.
- Pull the starter cord until the engine starts.
- Allow engine to warm up for a few minutes before using.
- Push the safety switch then the throttle trigger to start the operation

b. Stopping the operation

- Release the throttle trigger.
- Let the tool to rum a few minutes.
- Switch off the tool by putting the Start/stop switch on the position O (OFF).

c. Grass trimmer operation

■ Trimming

Tilt the head slowly to direct debris away from you. If cutting up to a barrier such as fence, wall or tree, approach from an angle where any debris ricocheting off the barrier will fly away from you. Move the line head slowly until the grass is cut right up the barrier, but do not jam (overfeed) the line into the barrier. If trimming up to a wire mesh or chain linked fence be careful to feed only up to wire. If you go too far the line will snap off around the wire. Trimming can be done to cut through weed stems one at a time. Place the trimmer line head near the bottom of the weed-never high up which could cause the weed to chatter and catch the line. Rather than cut the weed right through, just use the very end of the line to wear through the stem slowly.

■ Scalping and edging

Both of these are done with the line head tilted at a steep angle. Scalping is removing top growth without damaging the ground.

Edging is trimming the grass back where it has spread over a sidewalk or drive way. During both edging and scalping, hold the unit at a steep angle and in a position where the debris, and any dislodging dirt and stones, will not come back towards you even if it ricochets off the hard surface. Although the picture shows how to edge and scalp every operator must find for himself the angles which suits his body size and cutting situation.

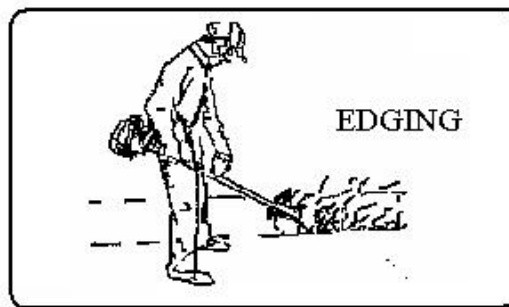
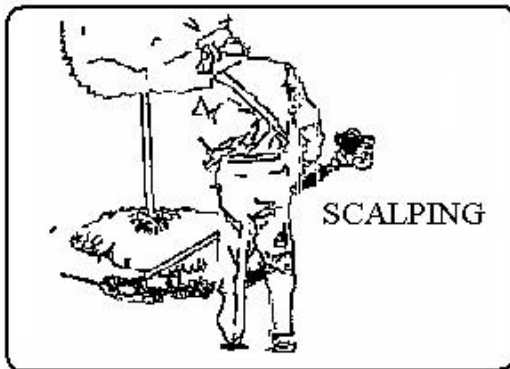

d. Brushcutter operation

- Do not use the brushcutter for cutting trees
- Do not cut with dull, cracked or damaged blade.
- Before cutting growth, inspect for obstructions such as boulders, metal stakes or strands of wire from broken fences. If an obstruction cannot be removed, mark its location so that you can avoid it with the blade. Rocks and metal will dull or damage a blade. Wire can catch on the blade head and flap around or be thrown into the air.
- Use the shoulder harness at all times adjust both harness and harness clamp on the unit so that the unit hangs a few inches above ground level. The cutting head and the debris shield should be level in all directions. Harness the unit on the right side of your body.
- Cut only with the side of the blade that the debris is moving away from you.
- If kickback occurs, the blade may be dull, or the material so thick and hard that you should use other tool instead of this machine.
- Do not force the blade to cut. Do not change the angle of cut after into the wood. Avoid using any pressure or leverage which could cause the blade to bind or crack.

■ Scything weeds

This is cutting by swinging the blade in a level arc. It can quickly clear areas of field grass and weeds. Scything should not be used to cut large, tough weeds or woody growths.

Scything can be done in both directions, or just in one way which results in the debris being thrown away from you.

That is using the side of the blade that it is rotating away from you. Tilt down the blade slightly on this same

side. You will be hit by some debris if you scythe in both directions.

Cut only with the side of the blade that the debris is moving away from you.

If kickback occurs, the blade may be dull, or the material so thick and hard that you should use other tool instead of this machine.

Do not force the blade to cut. Do not change the angle of cut after into the wood. Avoid using any pressure or leverage which could cause the blade to bind or crack.

6. MAINTENANCE & CARE

Before any maintenance work, the machine must be switched off and completely cooled.

Maintenance shall be provided regularly and must be done according to the instructions provided in this instruction manual. A clean, well-maintained machine increases its lifetime and efficiency.

Improper maintenance can cause damage, accidents and render the tool inoperable in the short term.

Any other maintenance, modification or repair must be carried out by a qualified professional.

Do not immerse the tool in water or any other liquid.

a. Air filter

Check the air filter as often as necessary to maintain in a clean condition. Light surface dust can readily be removed by tapping the filter. Heavy deposits should be washed out in suitable solvent. To clean the filter, remove filter cover by loosening air filter cover knob.

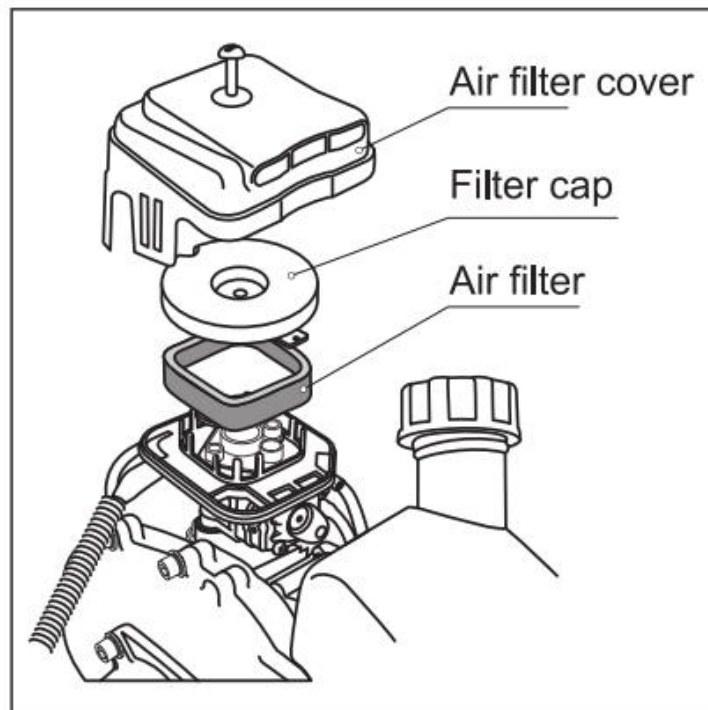

b. Adjusting the carburettor

Do not adjust carburettor unless necessary. If you have trouble with the carburettor, see your dealer. Improper adjustment may cause engine damage and void warranty.

c. Fuel filter

Fuel tank is fitted with a filter. Filter is situated at the free end of fuel pipe. It can be picked with a hook or similar device. Check the fuel filter periodically. Do not allow dust to enter into fuel tank. Clogged filter will cause difficulty in starting engine or abnormalities in starting engine or abnormalities in engine performance. When filter is dirty, replace the filter. When the inside of the fuel tank is dirty, it can be cleaned by rinsing the tank with gasoline.

d. Spark plug

The tool must be completely cold before manipulating the park plug.

- Clean or replace the spark plug in case of ozone contamination.
- Replace the spark plug if the end of the center electrode is worn.

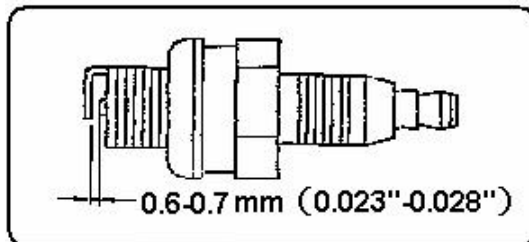

e. Replacement of the cutting string

- Push the tab which is on the housing cutting string and turn the cover to open it (see the markings on the housing).
- Remove the string and replace it by a new one.
- To reinstall the cutting string, first pass the two ends of the string on the holes localized on the housing.
- Put the cutting string in the housing; pull correctly the string outside of the tool in equal part.
- Place the cover on the housing; turn it to lock it in place.

f. Storage

- Inspect and clean the tool as explained in this manual.
- Empty fuel tank (it can be done by switching on the tool and let it consume all remaining fuel).
- Disassemble the accessories.
- Store the main unit and the accessories in a clean area, out of reach of children. It is recommended to place the tool and accessories in the original package.

7. TROUBLESHOOTING

PROBLEM	POSSIBLE CAUSE	CORRECTIVE ACTION
The unit does not start	The tool is not started in the correct way	Star the tool by following the instructions given in this manual
	Problem with the carburettor	The carburettor shall be inspected by an authorized service centre
	Spark plug is worn	Clean/gap or replace plug
	Fuel tank is empty	Fill fuel tank as described in this instruction manual
	Primer bulb was not enough pressed	Press the primer bulb fully and slowly 10 times
The unit starts with a low power	Fuel filter is plugged.	Replace the fuel filter.
	the choke lever is not positioned correctly	The choke lever should be on the OPEN position
	Dirty air filter	Clean the air filter as described in this instruction manual
	Problem with the carburettor	The carburettor shall be inspected by an authorized service centre
the engine sputters	Problem with the carburettor	The carburettor shall be inspected by an authorized service centre
	Air filter is blocked	Clean the air filter as described in this instruction manual
	Old or improperly mixed fuel	Fill fuel tank as described in this instruction manual
Runs erratically	The spark plug is not correctly gapped	adjust or replace the spark plug
	Dirty air filter	Clean the air filter as described in this instruction manual
Smokes excessively	Problem with the carburettor	The carburettor shall be inspected by an authorized service centre

8. DECLARATION OF CONFORMITY

DECLARATION OF CONFORMITY



BUILDER SAS

ZI, 32, rue Aristide Bergès – 31270 Cugnaux - France

Tel: +33 (0)5.34.502.502 Fax: +33 (0)5.34.502.503

Declares that the machines:

Brush Cutter & Grass Trimmer

Model: HDBT52-A

Serial No.: **20200833924-20200834378 / 20200834151-20200834378**

The people name holding the
Patriarca

Guaranteed sound power level	112 dB (A)
------------------------------	------------

technical file: M. Olivier

have been designed in compliance with the following standards:

EN ISO 11806-1:2011

EN ISO 14982:2009

And in accordance with the following directives:

Directive Machine 2006/42/EC

Directive EMC 2014/30/EU

Noise Directive 2000/14/EC Annex V & Directive 2005/88/EC

Emission directive 2016/1628/EU & 2018/989/EU

Philippe MARIE / PDG

Cugnaux, le **26/07/2020**

9. WARRANTY

HYUNDAI

WARRANTY

The manufacturer guarantees the product against defects in material and workmanship for a period of 2 years from the date of the original purchase. The warranty only applies if the product is for household use. The warranty does not cover breakdowns due to normal wear and tear.

The manufacturer agrees to replace parts identified as defective by the designated distributor. The manufacturer does not accept responsibility for the replacement of the machine, in whole or in part, and/or ensuing damage.

The warranty does not cover breakdowns due to:

- insufficient maintenance.
- abnormal assembly, adjustment or operations of the product.
- parts subject to normal wear and tear.

The warranty does not extend to:

- shipping and packaging costs.
- using the tool for a purpose other than that for which it was designed.
- the use and maintenance of the machine done in a manner not described in the user manual.

Due to our policy of continuous product improvement, we reserve the right to alter or change specifications without notice. Consequently, the product may be different from the information contained therein, but a modification will be undertaken without notice if it is recognized as an improvement of the preceding characteristic.

READ THE MANUAL CAREFULLY BEFORE USING THE MACHINE.

When ordering spare parts, please indicate the part number or code, you can find this in the spare parts list in this manual. Keep the purchase receipt; without it, the warranty is invalid. To help you with your product, we invite you to contact us by phone or via our website:

- **+33 (0)9.70.75.30.30**
- **<https://services.swap-europe.com/contact>**

You must create a "ticket" via the web platform.

- Register or create your account.
- Indicate the reference of the tool.
- Choose the subject of your request.
- Describe your problem.
- Attach these files: invoice or sales receipt, photo of the identification plate (serial number), photo of the part you need (for example: pins on the transformer plug which are broken).



10. PRODUCT FAILURE

WHAT TO DO IF MY MACHINE BREAKS DOWN?

If you bought your product in a store:

- a) Empty the fuel tank.
- b) Make sure that your machine is complete with all accessories supplied, and clean! If this is not the case, the repairer will refuse the machine.

Go to the store with the complete machine and with the receipt or invoice.

If you bought your product on a website:

- a) Empty the fuel tank.
- b) Make sure that your machine is complete with all accessories supplied, and clean! If this is not the case, the repairer will refuse the machine.
- c) Create a SWAP-Europe service ticket on the site: <https://services.swap-europe.com> When making the request on SWAP-Europe, you must attach the invoice and the photo of the nameplate (serial number).
- d) Contact the repair station to make sure it is available before dropping off the machine.

Go to the repair station with the complete machine packed, accompanied by the purchase invoice and the station support sheet downloadable after the service request is completed on the SWAP-Europe site

For machines with engine failure from manufacturers BRIGGS & STRATTON, HONDA and RATO, please refer to the following instructions.

Repairs will be done by approved engine manufacturers of these manufacturers, see their site:

- <http://www.briggsandstratton.com/eu/fr>
- <http://www.honda-engines-eu.com/fr/service-network-page;jsessionid=5EE8456CF39CD572AA2AEEDFD290CDAE>
- <https://www.rato-europe.com/it/service-network>

Please keep your original packaging to allow for after-sales service returns or pack your machine with a similar cardboard box of the same dimensions.

For any question concerning our after-sales service you can make a request on our website <https://services.swap-europe.com>

Our hotline remains available at +33 (9) 70 75 30 30.



11. WARRANTY EXCLUSIONS

THE WARRANTY DOES NOT COVER:

- Start-up and setting up of the product.
- Damage resulting from normal wear and tear of the product.
- Damage resulting from improper use of the product.
- Damage resulting from assembly or start-up not in accordance with the user manual.
- Breakdowns related to carburetion beyond 90 days and fouling of carburetors.
- Periodic and standard maintenance events.
- Actions of modification and dismantling that directly void the warranty.
- Products whose original authentication marking (brand, serial number) has been degraded, altered or withdrawn.
- Replacement of consumables.
- The use of non-original parts.
- Breakage of parts following impacts or projections.
- Accessories breakdowns.
- Defects and their consequences linked to any external cause.
- Loss of components and loss due to insufficient screwing.
- Cutting components and any damage related to the loosening of parts.
- Overload or overheating.
- Poor power supply quality: faulty voltage, voltage error, etc.
- Damages resulting from the deprivation of enjoyment of the product during the time necessary for repairs and more generally the costs related to the immobilization of the product.
- The costs of a second opinion established by a third party following an estimate by a SWAP-Europe repair station
- The use of a product which would show a defect or a breakage which was not the subject of an immediate report and/or repair with the services of SWAP-Europe.
- Deterioration linked to transport and storage*.
- Launchers beyond 90 days.
- Oil, petrol, grease.
- Damages related to the use of non-compliant fuels or lubricants.

* In accordance with transport legislation, damage related to transport must be declared to carriers within 48 hours maximum after observation by registered letter with acknowledgement of receipt.

This document is a supplement to your notice, a non-exhaustive list.

Attention: all orders must be checked in the presence of the delivery person. In case of refusal by the delivery person, it you must simply refuse the delivery and notify your refusal.

Reminder: the reserves do not exclude the notification by registered letter with acknowledgement within 72 hours.

Information:

Thermal devices must be wintered each season (service available on the SWAP-Europe site). Batteries must be charged before being stored.

HYUNDAI
POWER PRODUCTS

For Inquiries, please contact:

BUILDER SAS

32, rue Aristide Bergès Z1 31270 Cugnaux, France

Tél. : +33 (0) 5.34.502.502 Fax : +33 (0) 5.34.502.503

<http://www.hyundai-power-fr.com/>

Fabriqué en République Populaire de Chine (PRC)